

VIKING

Blast & Wash Systems

TABLE BLAST SYSTEMS

60T Shown
with Options
for Shot
Peening
Applications



Viking's Table Blast models are the ideal choice for a wide variety of parts that are not suitable for tumbling due to size and shape. Parts are rotated on the table and are cleaned by exposure to the abrasive blast.

72T
Shown



STANDARD FEATURES:

- Wrap around door allows easy access for loading and unloading parts
- Direct impingement areas in line with the blast stream are lined with 1/2" thick, 12" x 12" replaceable cast chrome/moly liners
- Safety interlock to prevent opening of the blast cabinet door during operation, protecting the operator from harm
- Fully adjustable lip type airwash separator ensures optimal abrasive cleaning.
- Low abrasive sensor and warning light on the electrical panel



Table is lined with a self-draining, 3/8" thick manganese alloy plate

CALL 1-800-835-1096



731 S. Industrial CT, Rose Hill, KS 67133
Website: www.vikingcorporation.com

Phone: 316-634-6699 Fax: 316-634-6658
Email: sales@vikingcorporation.com

TABLE BLAST SYSTEMS



SPECIFICATIONS:	36T	48T	60T	72T
Table Capacity	2,000 lbs.	2,500 lbs.	3,000 lbs.	4,000 lbs.
Work Envelope	36" Dia. x 34" H	48" Dia. x 34" H	60" Dia. x 48" H	72" Dia. x 60" H
Overall Dimensions	84"L x 48"W x 144"H	84"L x 48"W x 144"H	96"L x 84"W x 168"H	116"L x 84"W x 180"H
Electrical	240V or 460V, 3-PH	460V, 3-PH 60 HZ	460V, 3-PH 60 HZ	460V, 3-PH 60 HZ
Abrasive Required	600 lbs.	1,000 lbs.	1,000 lbs.	1,700 lbs.
Lip Type Airwash Separator	20"	20"	20"	20"
Blast Wheels:				
Number of Wheels	1	1	2	2
Horsepower	10 HP	20 HP	10 HP	15 HP
Diameter	15"	15"	15"	15"
R.P.M	3,600	3,600	3,600	3,600
Manganese Cabinet Construction	1/4-1/2"	1/4-1/2"	1/4-1/2"	1/4-1/2"
Floor Space Required	96"W x 72"L	120"W x 84"L	10"W x 8'D x 15'H	12"W x 12'L x 15'H
Shipping Weight	4,350 lbs.	5,700 lbs.	9,200 lbs.	14,000 lbs.

Additional Options Available:

- Dust collection system
- Rotary scalp drum
- UL approved electrical panel
- Sweco abrasive separator
- Auxiliary abrasive hopper and low level sensor
- Magna-valve brand electromagnetic shot valves and controller for abrasive flow control

Viking Blast & Wash Systems offers a full line of table blast systems. Larger machines with 96-inch diameter tables and up are available

It is in the customization of our basic designs to your parts specific needs that truly sets Viking apart from the competition. With an accomplished and proven design staff, Viking can build equipment from the ground up or simply modify existing models to tailor fit your cleaning application. At Viking we do not simply match your part to the closest machine size that will work. We match our blast equipment to your part, to provide the most efficient and economical cleaning solution possible.

VIKING OFFERS A FULL LINE OF AIRLESS SHOT BLAST & PARTS WASH EQUIPMENT



Basket Blasters



Chainbelt Pass-Thru Washers



Tumble Blasters



Parts Washers



Spinner Hangers



Monorail Pass-Thru Washers

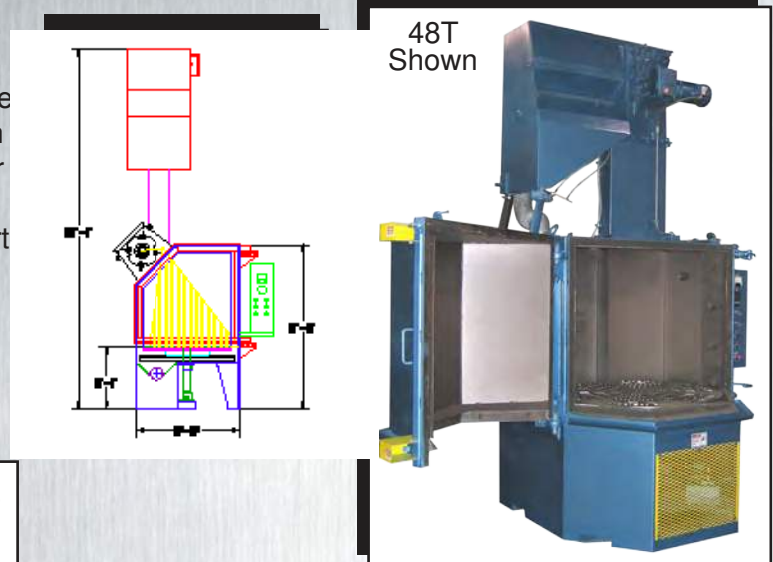

VIKING BLAST AND WASH SYSTEMS RESERVES THE RIGHT TO CHANGE ITS PRODUCTS OR SPECIFICATIONS AT ANY TIME WITHOUT NOTICE OR OBLIGATION. All machines are equipped with guards and safety devices to comply with State and Trade Regulations for the protection of operators. All electrical wiring is designed to conform with the protection of operators. Viking Blast and Wash Systems, or any of its divisions will not assume responsibility in cases of failure by the operator to exercise reasonable care when using the equipment.

VIKING BLAST AND WASH SYSTEMS
 731 S. Industrial CT, Rose Hill, KS 67133
 Phone: 316-634-6699 Fax: 316-634-6658
 Toll Free: 800-835-1096
 Email: sales@vikingcorporation.com
 Web: www.vikingcorporation.com