

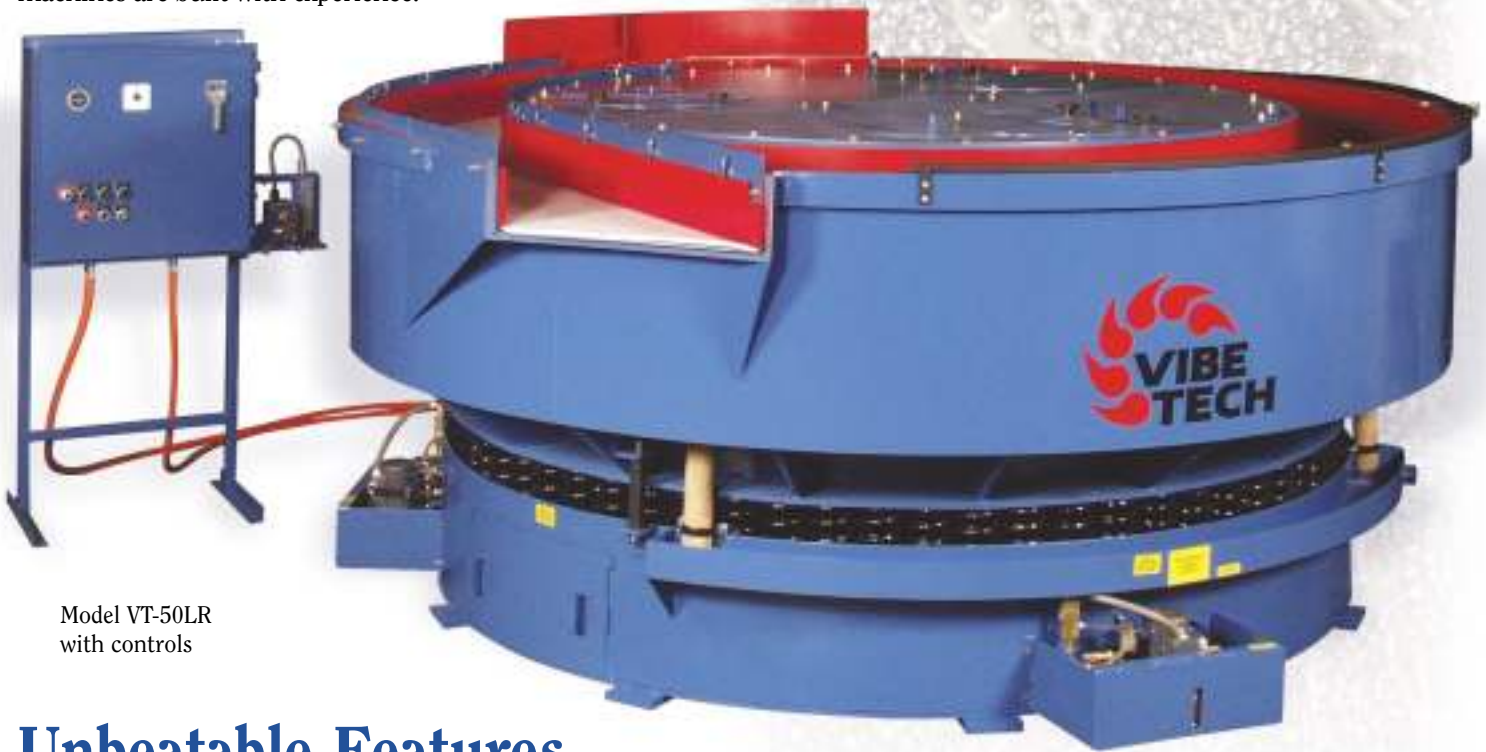

Vibratory Long Radius Finishing Equipment

Since 1965, the founders of CLM VIBETECH, Inc. have produced, serviced, repaired and restored Vibratory Equipment. Drawing on the experience from working on almost every brand of vibratory machines, CLM VIBE TECH Inc. has designed a full line of vibratory equipment using the best features available in today's industry. As a customer said after seeing all the brands in the plant for repair, "Looks like you build the best and fix the rest". That statement is very true. From the inside out our machines are built with experience.



Model VT-50LR
with controls

Unbeatable Features...

- Industry's best designed and proven oil lubricated drive system incorporates double-row spherical bearings, large heavy-duty shaft and a thick-walled cartridge. (Grease lubrication system on small capacity models.)
- All heavy-duty welded construction.
- Minimum 1" thick premium polyurethane lining (three grades available including hot pour).
- Exterior mounted components provide easy access for maintenance and service.
- Extra large springs for durability.
- Control panels are built to our customers requirements, from simple push button starters to fully automated PLC controls with digital displays.
- All long radius finishers are specifically designed for steel ball burnishing or continuous operations.
- Our long radius finishers have superior unloading and roll characteristics over a standard finisher
- On models with separation, there is a helical rise to aid unloading.
- Standard models, from 5 cu. ft. to 50 cu. ft., are custom designed to meet your application requirements.
- Continuous operations ranging from 2 min. up to 14 min.
- Most items needed for maintenance are available locally or on our shelf. We have the fewest custom made parts in the industry.

Designed better to last longer..

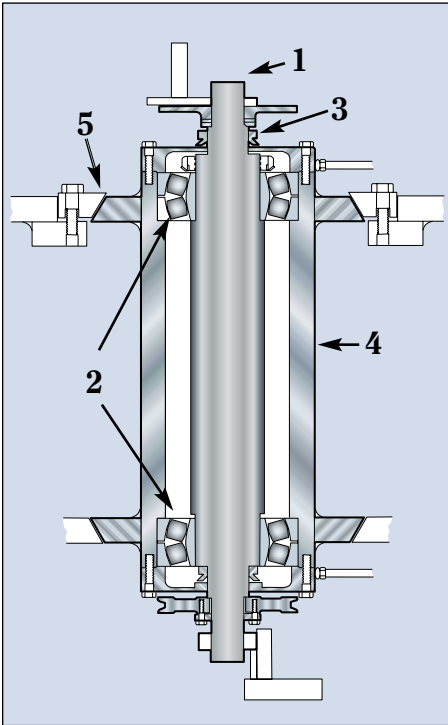

The heart of our oil lubricated vibratory long radius finisher is the drive cartridge...

1. Heavy-duty, over-sized, precision machined drive shaft.
2. Highest quality double-row spherical bearings are fitted to drive shaft, with clearance to allow for heat expansion, unlike pressed bearings that can build-up heat and reduce bearing life.
3. Lightweight non-abrasive seals will never damage shaft.
4. For service, our extra-heavy walled cartridge is the most easily accessible and removable cartridge in the industry.
5. Tapered drive clips are pulled down with grade 9 bolts, superior to relying on bolt shear strength.

The conical structure and the center tube are designed to optimize the transfer of energy from the drive cartridge to the process channel by distributing it correctly and without unnecessary stress to the structure.

Long Radius

Finisher Options:

- Pneumatic Gates • PLC Automation
- Media Classifying • Rinse Bars
- Air Knife • Extended Screen Decks
- Step-down Screens • Gate Clearing
- Variable Speed • Sound Covers
- Settling Tanks • Oil Skimmers
- Waste Water Treatment • Material Handling

Accessories for all makes:

- Drains • Gates • Compound System
- Screens • Noise and Dust Covers

Services:

- **Process Evaluation:** send us your sample parts for a free process evaluation.
- **System Design:** we can design and build custom systems from simple batch processes to fully automated systems.
- **Vibratory Equipment Repair:** we service all makes and models of vibratory equipment from basic repair to complete restoration.
- **Relining:** on all makes and models, 3 grades of urethane available from cold to hot pour.

For Service Call... 1-800-741-0670

Specification and Dimensions

Model	VTG-5LR	VT-10LR	VT-20LR	VT-30LR	VT-40LR	VT-50LR
Capacity (cu. ft.)	5	10	20	30	40	50
Motor Hp (A)	5	7.5	20	20	30	30
Number of drain	2	2	3	3	4	4
Lubrication system (C)	Grease	Auto Oil	Auto Oil	Auto Oil	Auto Oil	Auto Oil
Discharge height (D)	32"	42"	48"	50"	52"	54"
Channel width (E)	9.5"	11"	13"	15"	16.5"	17.5"
Overall diameter (F)	55"	68"	92"	116"	124"	136"
Overall height (G)	39"	50"	58"	60"	62"	64"
Foot print	5' x 5'	6' x 6'	8' x 8'	10' x 10'	11' x 11'	12' x 12'

Due to on going design improvements, design and specifications are subject to change without notice.

In addition to our line of Long Radius Finishers we have a full line of; Vibratory Finishers, Vibratory Dryers, Vibratory Combos; Finisher/Dryer, Helix Finishers; for continuous operations, Tub Finishers; for batch processes

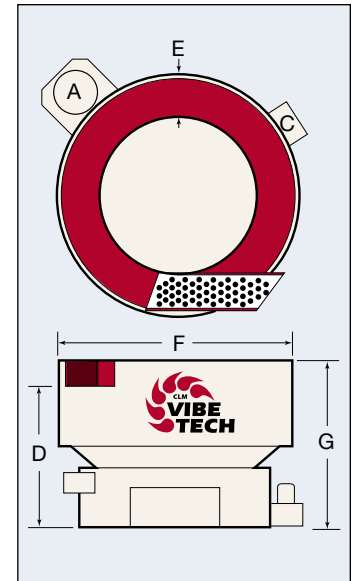

Distributed by:



7025 East K Avenue
Kalamazoo, Michigan 49048
Ph: 269-344-3878 Fax: 269-344-3088